





Hydraulic Mortuary Transport and Lifting Trolley Hydraulischer Leichenmulden-Transporthubwagen



HTW HS 200

Description Beschreibung

Torsion free steel construction, hammer finish stove enameling in silver. Built-in hydraulic with ergonomic hydraulic lift system. The top section comes with lockable rolls to allow reception of mortuary trays. The chassis features 200 mm rolls and an extra short wheel distance. This makes it very easy to handle and will be a helpful transporter for in-house usage. Various options are additionally available.

Stabile, verwindungsfreie Stahlkonstruktion mit Einbrennlackierung in Hammerschlag Silber. Integrierte Hydraulik für leichtgängige und stufenlose Höhenverstellung per Fußpedal. Integriert ist ein Trägersystem mit Rollen zur Aufnahme von Leichenmulden und Seziertischplatten. Das Fahrgestell hat ø 200 mm Rollen mit extra kurzem Radstand. Der Wagen ist somit wendiger und ideal für den in-house-Transport zwischen Kühlzelle und Seziertisch. Verschiedenes Zubehör ist optional erhältlich.

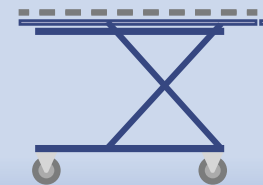

L x W x H approx.

2034 x 710 x 452-1670 mm

L x B x H ca.



Lockable roller conveyor
Arretierbare Rollenauflage



Security lock for body tray
Sicherungsverschluß für Leichenmulde



Short wheel base for more agility
Kurzer Radabstand für mehr Beweglichkeit



Lifting height/ Hubhöhe		Standard/ Normal	Stainless steel Edelstahl	Scale Waage
1250 mm	Order No. Best. Nr.	HTW HS 200	HTW HS 200 C	HTW HS 200 W
1430 mm	Order No. Best. Nr.	HTW HS 200 S	HTW HS 200 S C	HTW HS 200 S W
1600 mm	Order No. Best. Nr.	HTW HS 200 SS	HTW HS 200 SS C	HTW HS 200 SS W
1670 mm	Order No. Best. Nr.	HTW HS 200 SSS	HTW HS 200 SSS C	HTW HS 200 SSS W
Standard: hammer finish stove enameling in silver Normal: Hammerschlag, Silber einbrennlackiert				

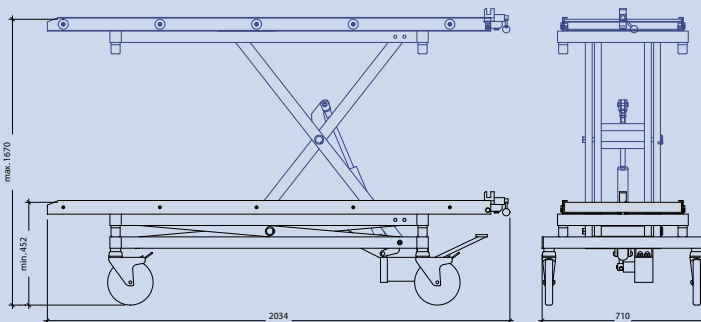

Specifications HTW HS 200

L /W/H1-H2 approx.: 2034 x 710 x 452-1670 mm
 Carrying capacity: max. 200 kg
 Tare: approx. 86 kg
 Wheels: 200 mm

Technische Details HTW HS 200

L/B/H1-H2: ca.: 2034 x 710 x 452-1670 mm
 Tragkraft: max. 200 kg
 Leergewicht: ca. 86 kg
 Räder: 200 mm

On request the roller conveyor is available in changed dimensions.
 Auf Wunsch ist die oberseitige Rollbahn in geänderten Abmessungen lieferbar.

OPTIONAL



Digital Scale
 Elektronische Waage



Cover for Mortuary tray made from aluminum or stainless steel
 Abdeckhaube für Leichenmulde in Alu / CNS



Cover for Mortuary tray with embossing
 Geprägte Abdeckhaube für Leichenmulden, Edelstahl